

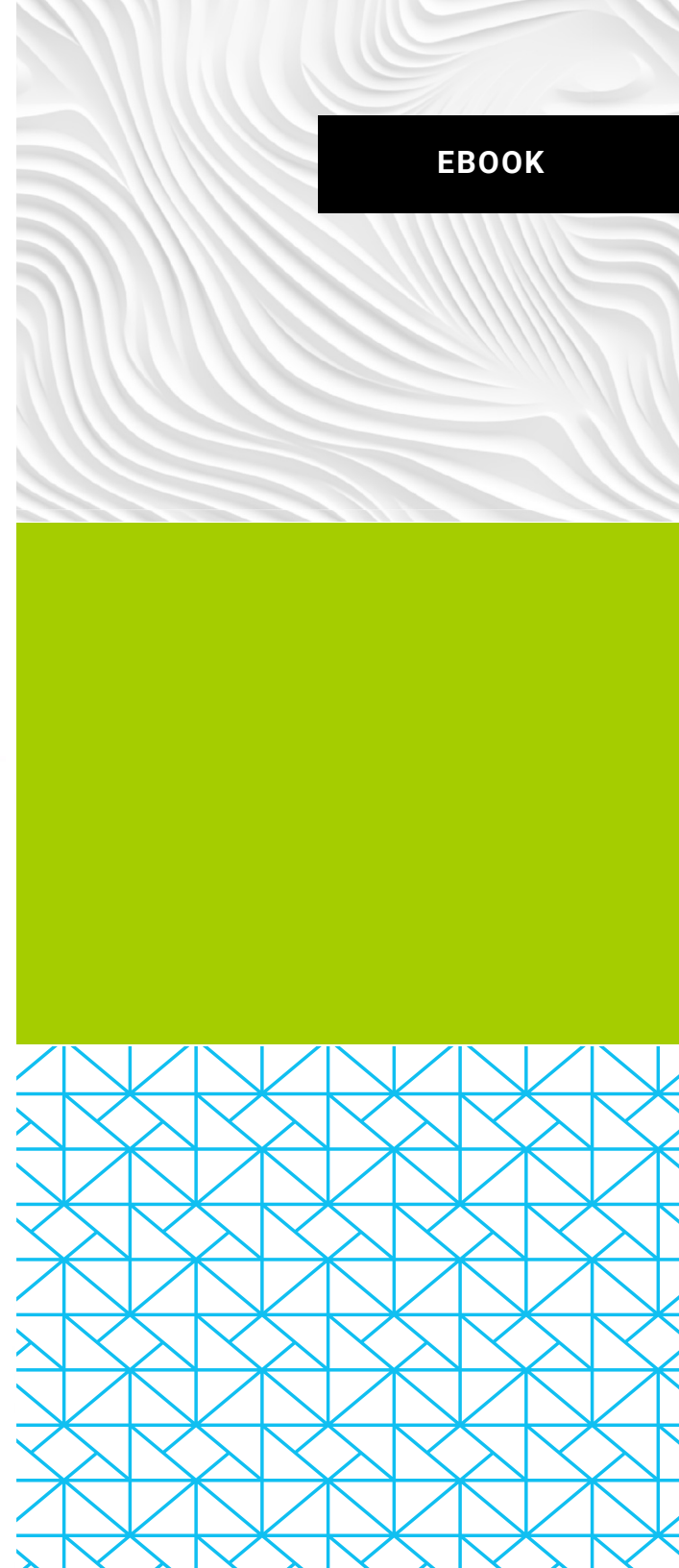

EBOOK

Serial Production with Additive Manufacturing

Comparing Parts Produced with DLP and LCD 3D Printing Technology





Comparing Parts Produced with DLP and LCD 3D Printing Technology

Are Both of These Additive Manufacturing Technologies Suitable for Serial Production?

Additive manufacturing processes for serial production of end-use parts must be fully controllable, ensuring you can consistently print accurate parts with defined tolerances, maintaining the physical properties of your prints. You also need the capability to repeat this process without restarting print preparation – whether it's the next day or the next month, on the same printer or a similar machine.

That said, product quality and performance are probably still at the top of your list. First and foremost, you need a technology that delivers the accuracy, precision, and tolerances that match your current traditional

manufacturing methods such as injection molding or CNC.

Resin 3D printing, or vat polymerization, is recognized as the most accurate and precise among 3D printing technologies, with DLP and LCD being faster alternatives to laser-based stereolithography (SLA). Although they are considered similar and benchmarked against one another, DLP and LCD are in fact very different technologies. The most important question is: can both technologies produce parts with the required accuracy, surface finish and dimensional properties that industrial 3D printing demands? And can they do so consistently and repeatably?

There is only one way to find out. We had parts printed using both a DLP and an LCD system and then compared them thoroughly side by side. While this is only a preliminary comparison and not exhaustive, (spoiler alert) it is sufficient to provide a clear answer to the above question.

Let us take you through the results. If you want more details, or if your comparison showed a different outcome, we'd love to hear from you.

[Reach out through this form on our website.](#)

Scope and Methodology

Parts

Part geometry and shape can significantly influence the outcome of a print, and certain technologies may be more suited for certain geometries. So we decided to print four parts to represent a broad range of part geometries and shapes.

These parts were selected for printing and comparison:

- Test part: a typical test part, chosen for a variety of design features and fine details, representative of high-quality end-use parts across use-cases.
- Industrial bracket: a well-known design in the industry for evaluating printing quality.
- Cylinder: demonstrates fine feature details, surface quality, accuracy, overhangs and slopes with a different orientation than the other parts
- Two-cavity mold inserts: a two-piece, bulky shape with a large cross-sectional area. Mold inserts are typically held to high standards for accuracy, tolerances, flatness, surface finish and performance.



Materials

The selected parts were printed using various materials, to observe possible variation in printing behavior and to rule out material as

a decisive factor. We used the same material where it was available on both printers. In cases where this was not possible, we used

the most comparable materials available for each system in terms of mechanical or physical properties:

Materials used to print parts on LCD and DLP printers

Type	DLP printer	LCD printer
General purpose (comparable materials)	ST45	xPP405
Tough (same material)	3843	xABS3843
Tough (comparable materials)	3843	xPEEK147
Tough (comparable materials)	3843	xPP405
High temperature (comparable materials)	3955	xPEEK147
High temperature (comparable materials)	403	xPEEK147

Printers

The four parts were printed on the following printers.

LCD (Liquid Crystal Display) - Nexa3D XiP Pro and NXE 400Pro

These run on Nexa3D's patented Lubricant Sublayer Photocuring (LSPc) technology, a VAT photopolymerization process based on LCD technology.

Parts were printed on two models: the Nexa XiP Pro and the NXE400 Pro. Both printers use the same underlying technology. Parts were

printed on one or both machines. The XiP Pro demonstrated superior quality vs the NXE 400 Pro, exhibiting slightly better base flatness and part quality. So we have only included the XiP Pro results in case of parts printed on both machines.

The parts were ordered from a service bureau recommended by the printer manufacturer, ensuring that they met the standard of quality representative of typical outcomes. This approach removes the possibility that the difference in quality could stem from a lack of experience printing with the technology.

DLP (Digital Light Processing) - Origin One

This system is powered by Stratasys P3™ DLP technology. The patented Programmable Photopolymerization is an evolution of the projector-based DLP technology invented by Texas Instruments.

The parts printed on the Origin One were printed in house at Stratasys.



Materials used to print parts on LCD and DLP printers

Type	DLP Printer - Origin One	LCD Printer - Nexa3D XiP Pro	LCD Printer - Nexa3D NXE400 Pro
Light Engine Source	<p>DLP</p> <ul style="list-style-type: none"> The resin is cured using a projector and DMD (Digital Mirror Device). Projected 50um pixel size No physical resolution limitations Minimal light bleed 	<p>LCD</p> <ul style="list-style-type: none"> The resin is cured using an LCD screen. Runs 750um pixel size Light bleeding between pixels (curing more than just pixel size) Fast pixel degradation LCD screen is a consumable. 	
Light Engine Precision	High irradiance – (~5mW/cm ²) Results in higher green-strength – fewer supports needed	Low irradiance – (~1mW/cm ²) <ul style="list-style-type: none"> Results in lower green-strength (parts are soft coming off the printer) Requires more supports Long post-cure times (30-120 minutes) 	
Build Volume	192x108x370 mm	292x163x410 mm	274x155x400 mm
Precision	Higher precision.	<ul style="list-style-type: none"> Lower precision, due to larger projected area. 	
Separation Mechanism	<p>P3 Pneumatic mechanism</p> <p>Lower separation forces means fewer supports and more geometrical freedom: from fine details to large cross-sectional areas.</p>	<p>Passive membrane</p> <ul style="list-style-type: none"> More geometry limitations Requires more and extensive supports Fine features and large cross-sections are difficult to print. 	
UV Wavelength	<p>385nm</p> <ul style="list-style-type: none"> Uses more expensive optics Reactivity peak of most resins is below 400nm. Better accuracy as UV light penetrates not as deep. 	<p>405nm</p> <ul style="list-style-type: none"> Uses cheaper optics Not all resins react (well) to wavelengths above 400nm. More susceptible to through-cure. 	
Pixel Size (XY)	50um DLP Pixel	46um LCD Pixel	76.5um LCD Pixel
Materials	14 validated materials, of which 3 are for prototyping. Additional 11 materials with the Open Material License	15 validated materials, of which 6 are for prototyping.	
Open Materials	Yes - with Open Material License	Yes	
Build Platform	Flat - Can print flat surfaces on build head	Perforated - Supports are always needed	
Heating	Yes (60°C)	No. - Limiting use of certain materials	
Price (USD)	<p>\$99,000</p> <p>Higher: more costly DMD (Digital Mirror Device) chip (by Texas Instruments); more costly optics</p>	<p>\$60,000</p> <p>Lower: cheaper optics</p>	\$42,000



Comparison

Upon receiving the parts, we conducted a side-by-side comparison and proceeded to benchmark them against each other.

We utilized the described methods to evaluate the following aspects:

▪ Part quality: visual inspection of the printed parts:

- Base flatness: Checked for signs of warping at the part base.
- Geometry: Examined for deformation, physical fit, and warping.
- Surface finish:
 - Assessed the smoothness of the surface in XY or Z-dimensions, and checked for any irregularities imperfections, or holes.
 - Looked for bleeding, skin on edges, pixelation, and other defects.
 - Noted print marks: visible support marks, printer lines/layers, tray sheet lines, holes, discoloration

▪ Dimensional properties

- Measured average absolute deviation using with calipers and a micrometer.
- Measured and compared dimensional accuracy of scanned printed part's point cloud vs the CAD model, using a GOM Atos Core 135 blue light 3D Scanner.

These methods allowed us to identify the differences in parts printed using two distinct technologies. Depending on user needs, more advanced methods can reveal further differences to assess the most suitable 3D printing technology for specific applications. That said, not all LCD systems and DLP systems are identical.

More Information

If your comparison showed different outcomes, or if you'd like to discuss additive manufacturing for your production needs, we'd love to hear from you.

[Please reach out via this form on our website.](#)





Comparing Parts Produced with DLP and LCD 3D Printing Technology

Base Flatness – Test Part



Origin One – ST45

Flat base

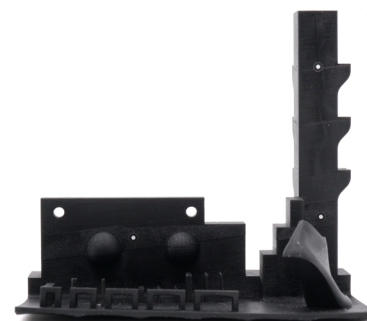

XiP Pro – xPP405

Severe warping in base

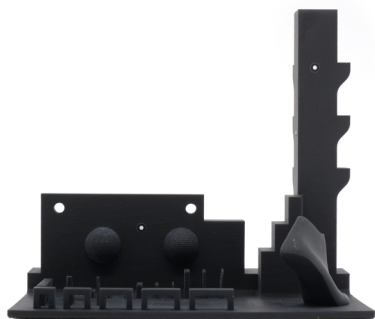

XiP Pro – xABS3843

Decent flatness

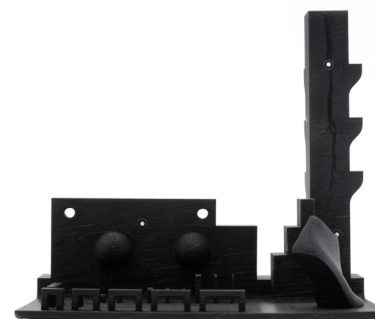

XiP Pro – xPEEK147

Slight warping



Surface Quality and Finish – Test Part

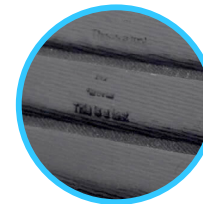
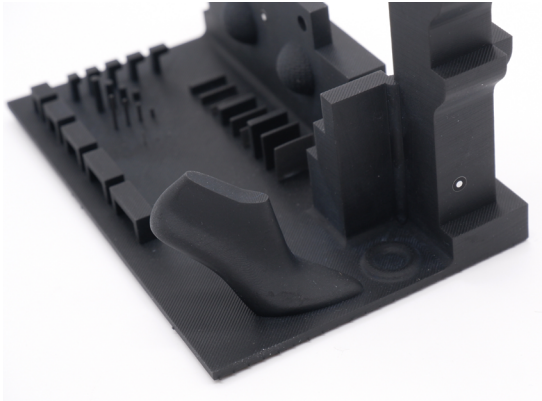

Muddy features resulting in unreadable text

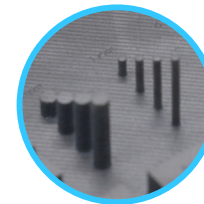

Very noticeable layer lines on flat surfaces.

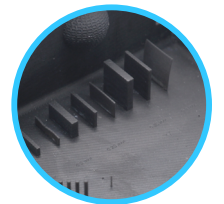

Warped thin walls

XiP Pro - xABS3843

Uneven and rough surface finish and multiple defects

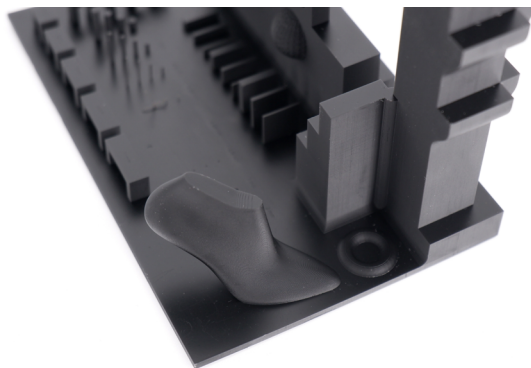

Origin One - 3843

Smooth surface finish



Surface Quality and Finish – Test Part

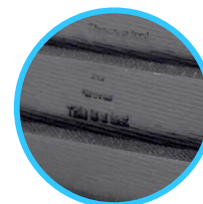

Muddy features resulting in unreadable text

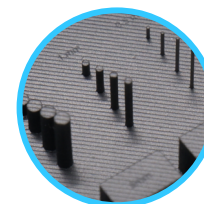

Very noticeable layer lines on flat surfaces.

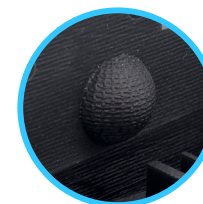

Transition line defect

XiP Pro – xPEEK147
Uneven and rough surface finish and multiple defects

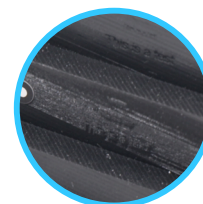
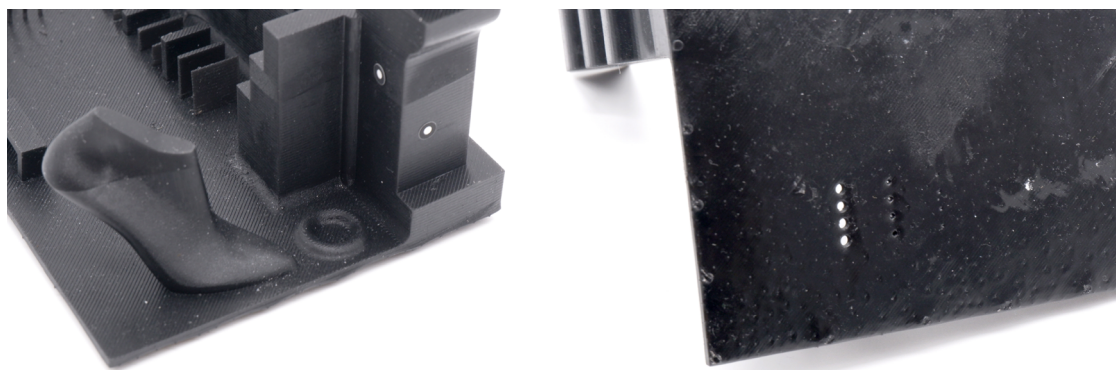

Surface defects and muddy features resulting in unreadable text

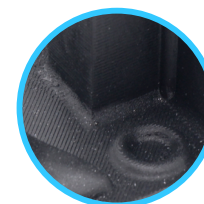

Very noticeable layer lines on flat surfaces.*

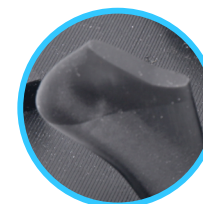

Transition line defect

XiP Pro – xPP405
Uneven and rough surface finish and defects. Layer lines are due to printing the part at an angle, most optimal on a solid build platform.



Part Quality – Industrial Bracket

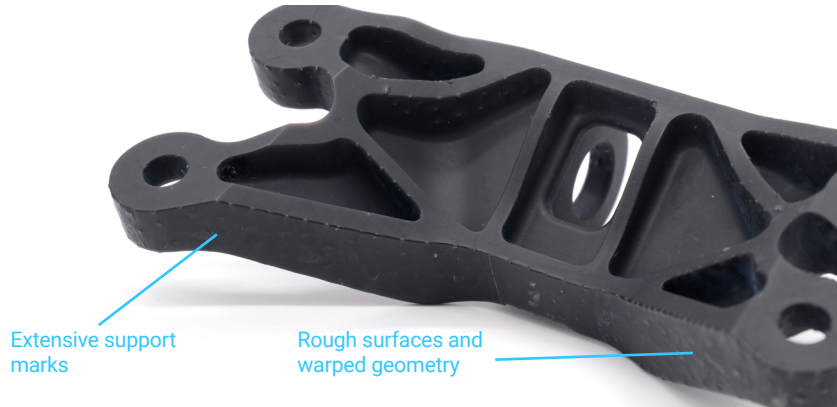

XiP Pro - xABS3843

Warped surfaces, artifacts and extensive support marks



Origin One – 3843

Smooth surface finish



Part Quality – Industrial Bracket



XiP Pro – xPP403

Warped surfaces, artifacts and extensive support marks



Origin One – 3843

Smooth surface finish



Part Quality – Industrial Bracket



XiP Pro – xPEEK147

Warped surfaces, artifacts and extensive support marks



Origin One – 3843

Very smooth surface quality without marks or deformations



Surface Finish, Accuracy – Overhang Cylinder High-Temperature Material

Upward slope is deformed



XiP Pro – xPEEK147

Origin One – 3955

NXE 400 Pro – xPEEK147

Origin One – 3955

No support marks on Origin part | Extensive support marks, uneven surface finish and deformations on XiP Pro and NXE 400 Pro parts



Surface Quality and Finish – Mold Core and Cavity, Bulky Part

Noticeable steps on upper surface finish



Origin One - 403
Smooth surface finish, no flaws

XiP Pro – xPEEK147
Uneven and rough surface finish and large gaps



Accuracy and Tolerance – Mold Core and Cavity, Bulky Part



Origin One - 403

Excellent fit



XiP Pro – xPEEK147

Poor fit, with large gaps



Dimensional Accuracy

Rigid and Tough Materials

Five parts were printed of each material on Origin One and compared to three parts of each material printed on Nexa3D NXE400 Pro

Measurements were taken using calipers and a micrometer.

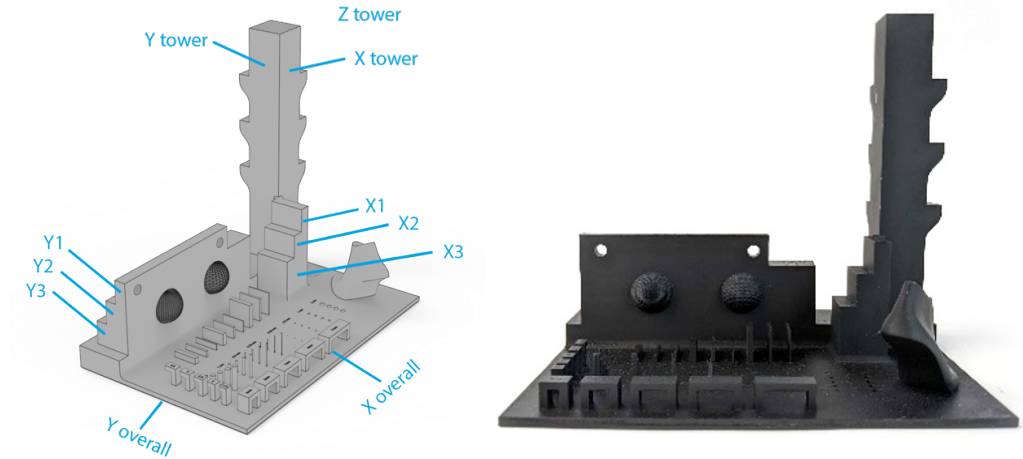

Average Absolute Deviation Across all Measured Features

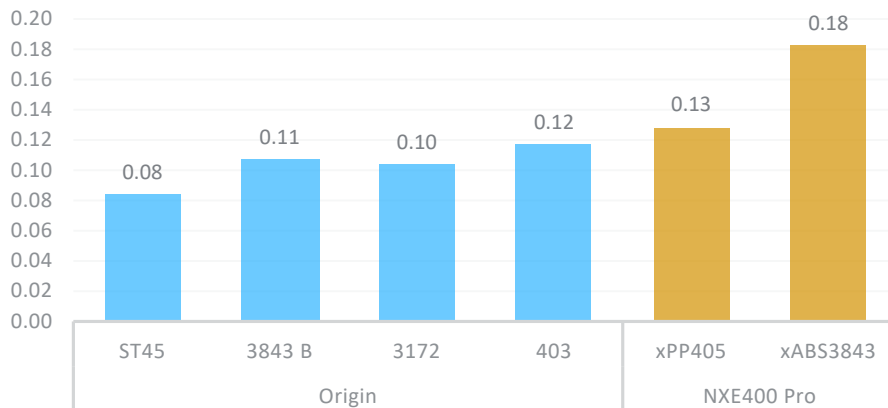

Average Percentage Deviation from Nominal

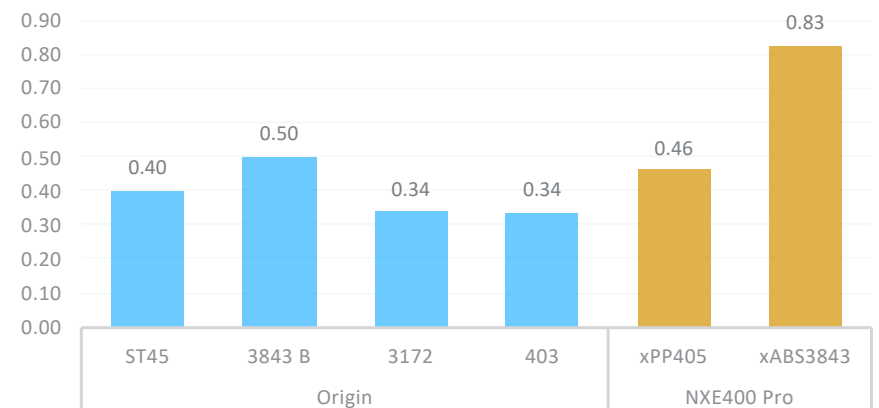



Dimensional Accuracy

High-Temp Materials

Five parts were printed of each material on Origin One and compared to three parts of each material printed on Nexa3D NXE400 Pro

Measurements were taken using calipers and a micrometer.

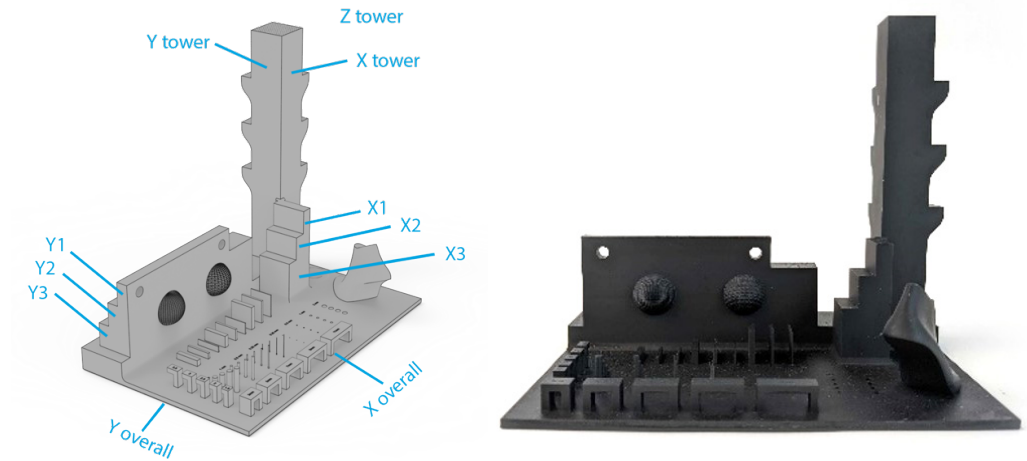

Average Absolute Deviation Across all Measured Features

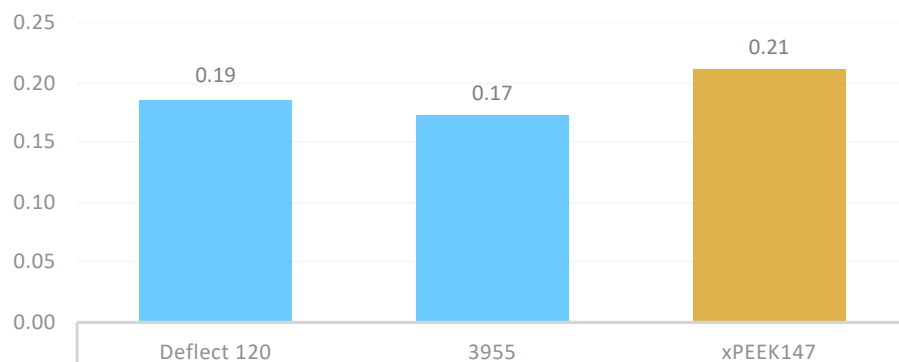

Average Percentage Deviation from Nominal

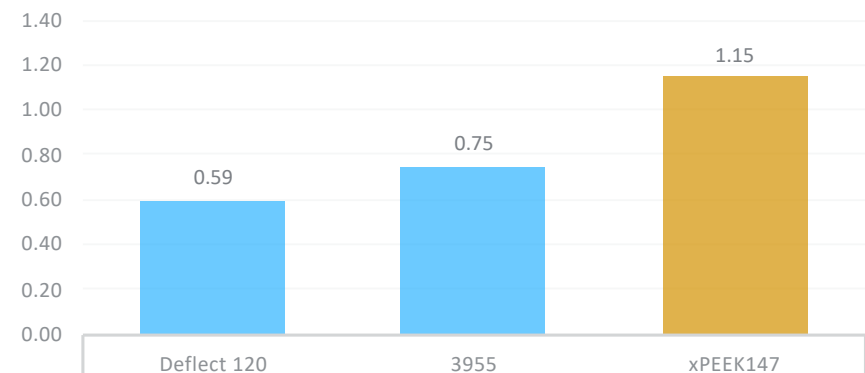



Dimensional Accuracy - Mold Core and Cavity, Bulky Part

Parts scanned using a GOM Atos Core 135 blue light 3D Scanner

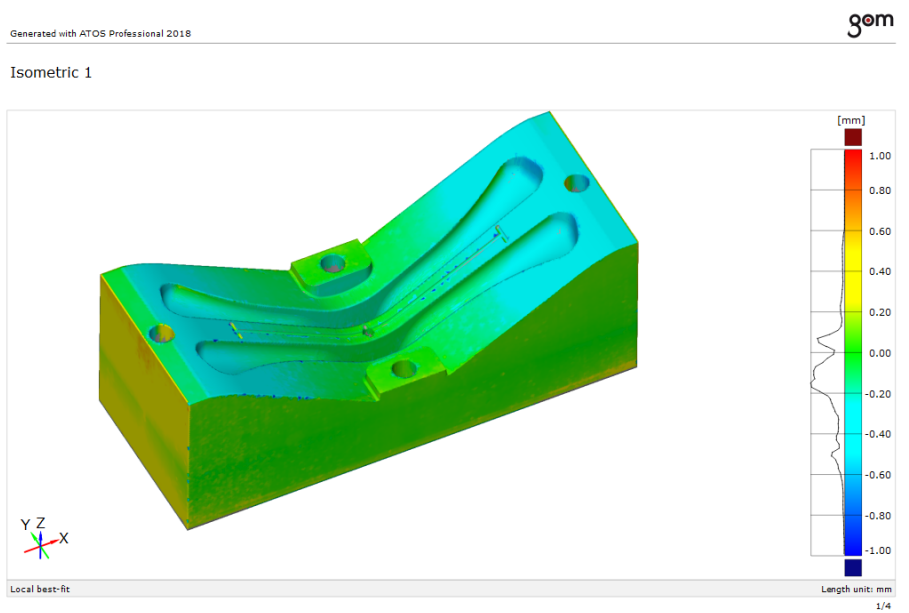

Origin One - 403
Geometry within required tolerance

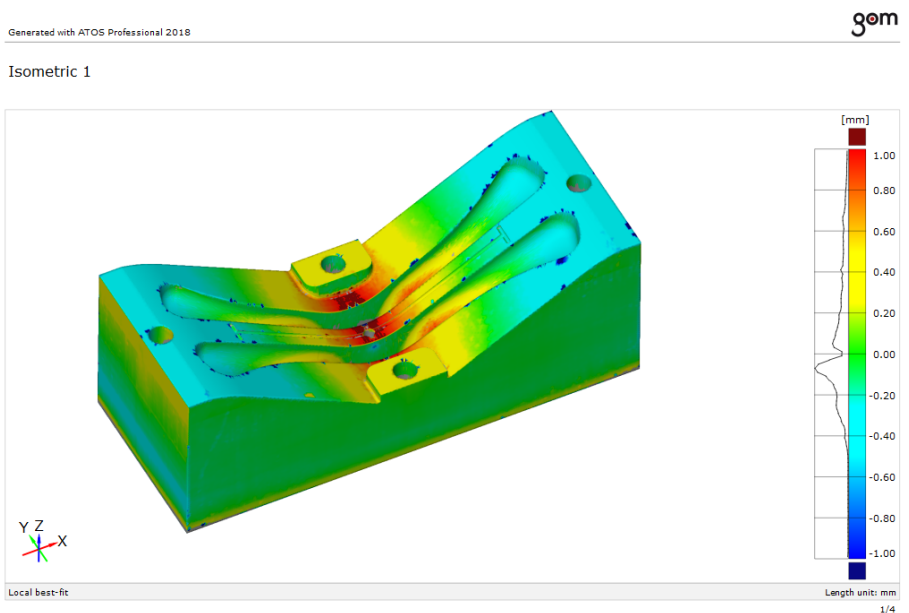

NXE400 Pro - xPEEK147
Critical geometry unusable



Dimensional Accuracy - Industrial Bracket

Parts scanned using a GOM Atos Core 135 blue light 3D Scanner

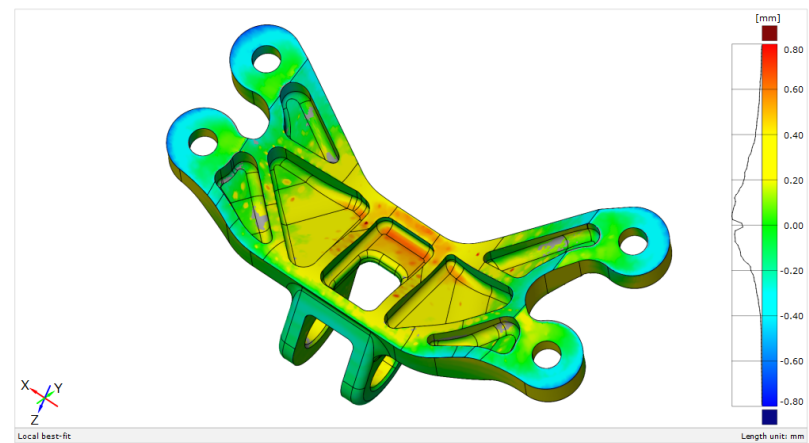
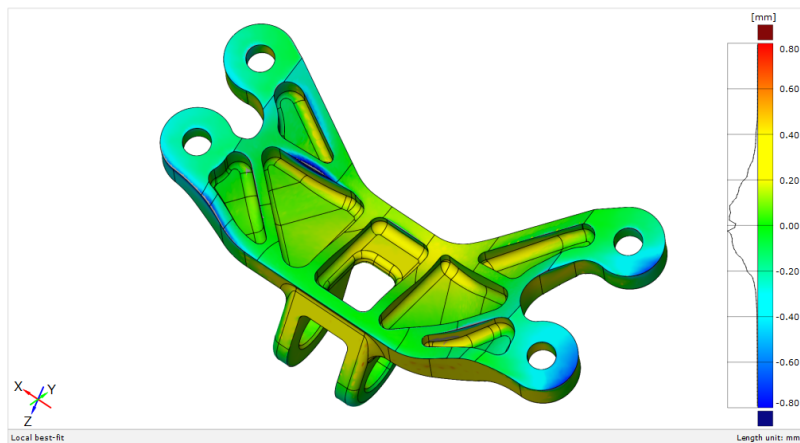
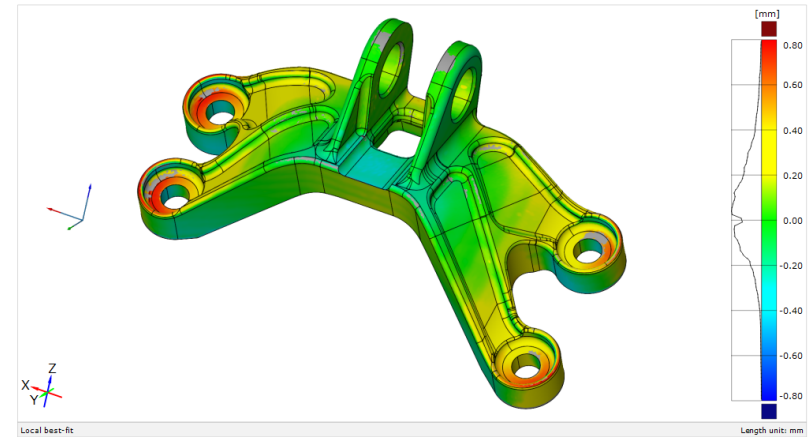
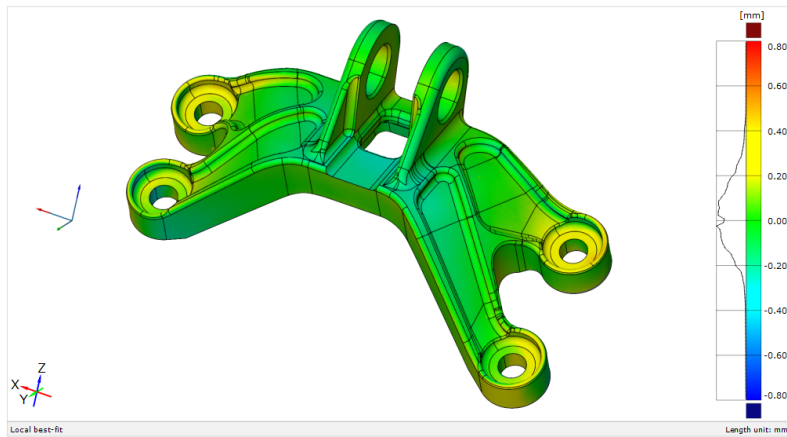

Origin One - 3843

83.2% of part within 0.2mm of nominal

NXE400 Pro - 3843

69.9% of part within 0.2mm of nominal

Dimensional Accuracy - Industrial Bracket

Parts scanned using a GOM Atos Core 135 blue light 3D Scanner

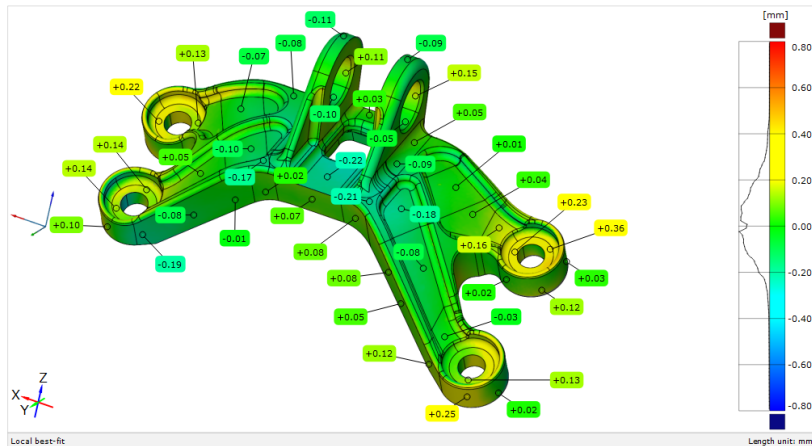

Origin One - 3843

83.2% of points less than 0.2mm of CAD

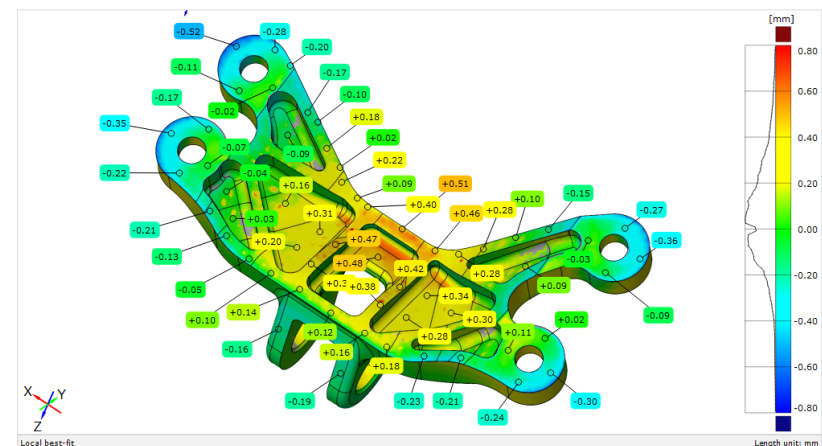

NXE400 Pro - 3843

69.9% of points less than 0.2mm of CAD

Want to read more about the differences between DLP and LCD and how to choose the right one for production?

[Check out this blog on DLP vs LCD.](#)

For more on photopolymer 3D printing technologies, we refer to: Haoyuan Quan [Et Al], "Photo-curing 3D Printing Technique and Its Challenges", in Bioactive Materials Vol. 5 Issue 1 (March 2020), p. 110-115.

Stratasys Headquarters

7665 Commerce Way,
Eden Prairie, MN 55344
+1 800 801 6491 (US Toll Free)
+1 952 937-3000 (Intl)
+1 952 937-0070 (Fax)

1 Holtzman St., Science Park,
PO Box 2496
Rehovot 76124, Israel
+972 74 745 4000
+972 74 745 5000 (Fax)

stratasys.com

ISO 9001:2015 Certified

